

# Swirl Diffusers

- with perforated sheet facing
- Type DCS

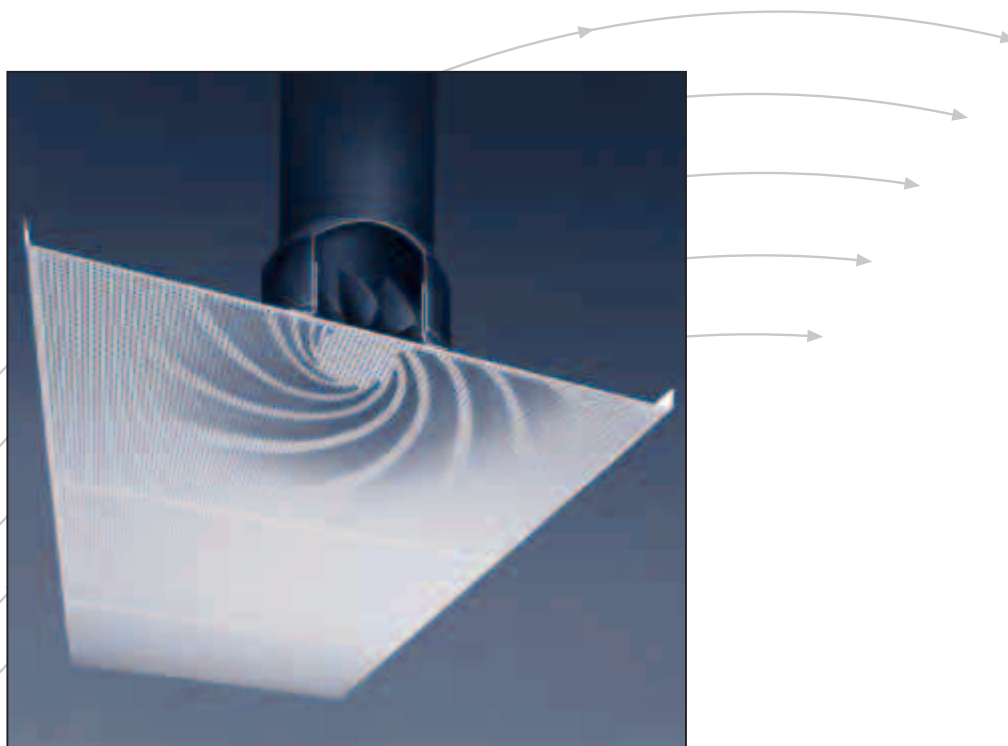

**TROX<sup>®</sup> TECHNİK**

TROX GmbH  
Heinrich-Trox-Platz  
D-47504 Neukirchen-Vluyn

Telephone +49/28 45/2 02-0  
Telefax +49/28 45/2 02-2 65  
e-mail [trox@trox.de](mailto:trox@trox.de)  
[www.troxtechnik.com](http://www.troxtechnik.com)

# Contents · Description

Description	2
Construction · Dimensions	3
Installation · Fixing	5
Materials	5
Nomenclature	6
Acoustic Data	7
Aerodynamic Data	8
Order Details	14

TROX swirl diffusers with perforated sheet facing are suitable for both comfort air conditioning and industrial applications. The construction of the diffuser results in a swirling rotational type of discharge of supply air, ensuring a high level of induction and a rapid reduction of jet air velocities and temperature differentials. Swirl diffusers can be used in either constant or variable air volume systems with excellent performance characteristics when air flow reduces from 100 % to 25 %.

Type DCS-P-...

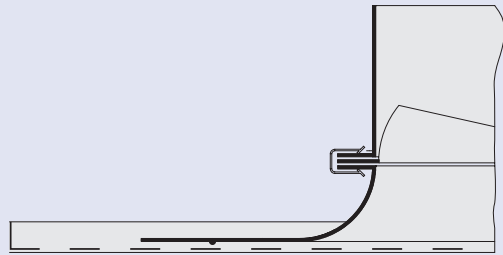
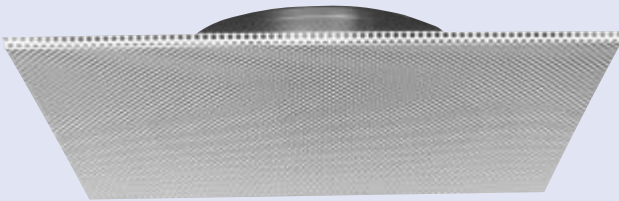

Type DCS-N-...

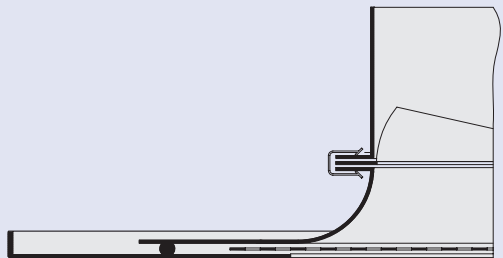
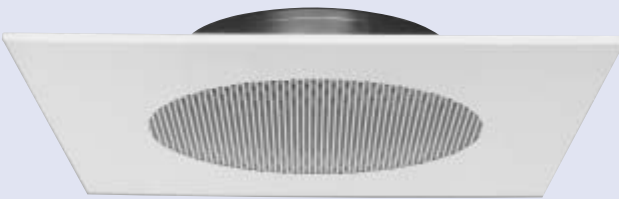

Type DCS-C-...

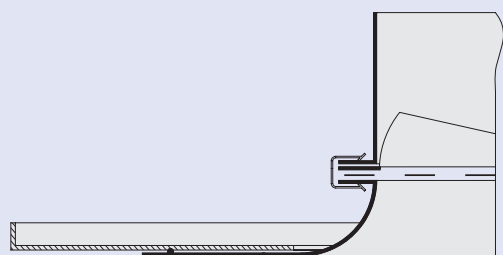
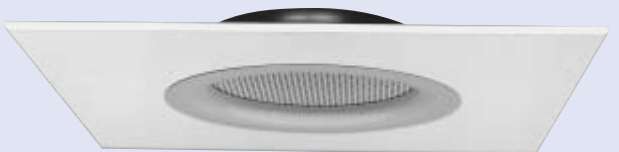

# Construction · Dimensions

## Construction

The DCS range of square diffusers is available in sizes ... x 125, 160, 200, 250, 315 and 400 with various face plate dimensions and designs.

Type DCS-P air diffusers consist of the perforated face plate with a thin acoustic fleece lining on the rear. In type DCS-N, the face plate is made of plain sheet steel with perimeter returned edge with central perforated plate insert.

The rear circular diffuser includes a discharge nozzle ring and radially arranged fixed air control blades and connection collar. If required, can be supplied with top entry spigot piece or side entry plenum box with circular spigot. Plenum box can have internal acoustic insulation if specified.

Size	Ø A	Ø B	Ø C	Ø D	H <sub>1</sub>	H <sub>2</sub>	H <sub>3</sub>	□ K	□ K <sub>1</sub>	Ø R
... x 125	123	200	175	98	156	76	154	180	202	200
... x 160	158	235	210	123	180	79	159	215	237	250
... x 200	198	275	250	158	215	79	162	255	277	300
... x 250	248	325	300	198	255	76	167	305	327	350
... x 315	313	410	385	248	305	89	184	370	392	450
... x 400	398	495	470	313	361	89	194	454	476	500

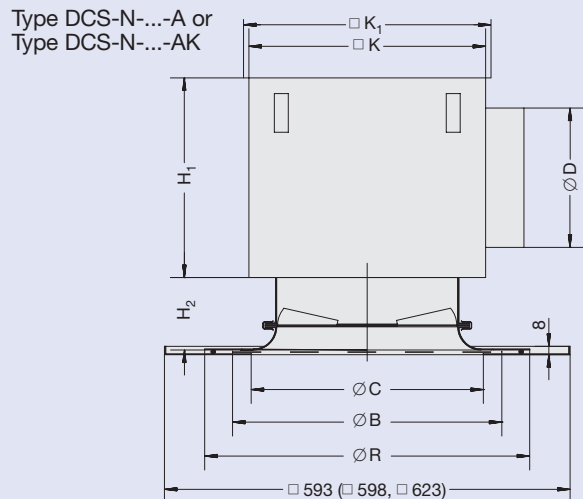
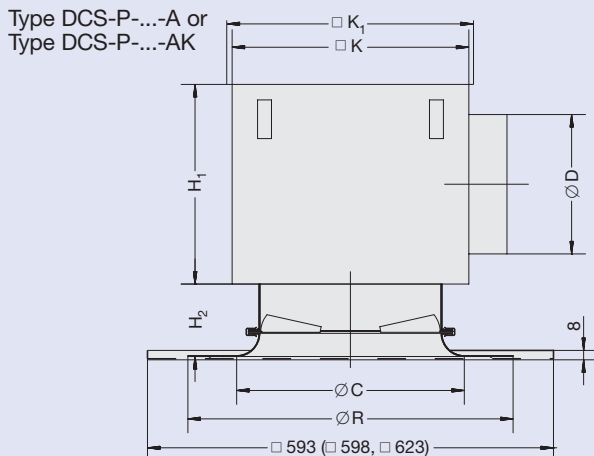
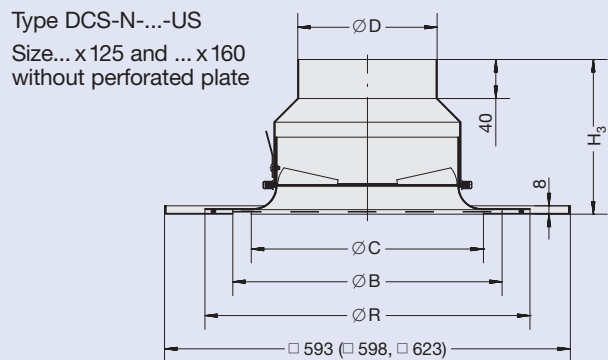
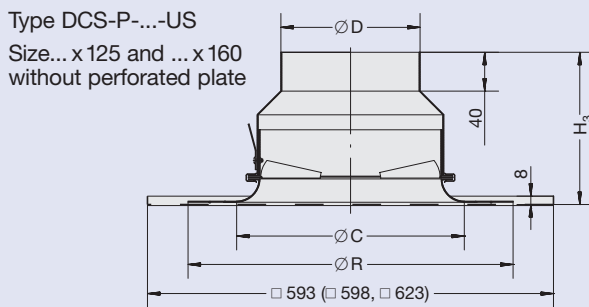
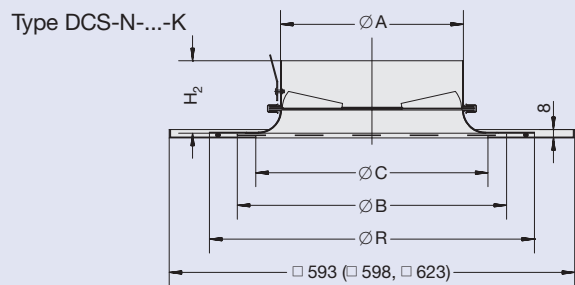
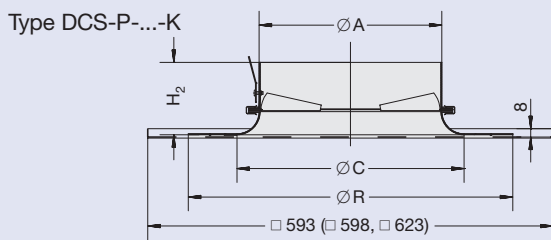

## Construction

Type DCS-C diffuser consists of a plain sheet steel face plate with perimeter returned edge. Fitted into this is a circular swirl diffuser consisting of discharge nozzle ring, recessed perforated plate, radially fixed air control blades and connection collar.

If required, can be supplied with top entry spigot piece or side entry plenum box with circular spigot. Plenum box can have internal acoustic insulation if specified.

Type DCS-C-...-K

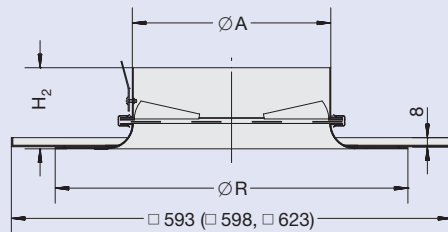

Type DCS-C-...-US  
Size ... x 125 and ... x 160  
without perforated plate

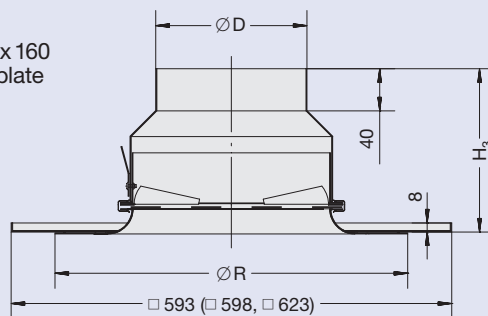

Type DCS-C-...-A or  
Type DCS-C-...-AK

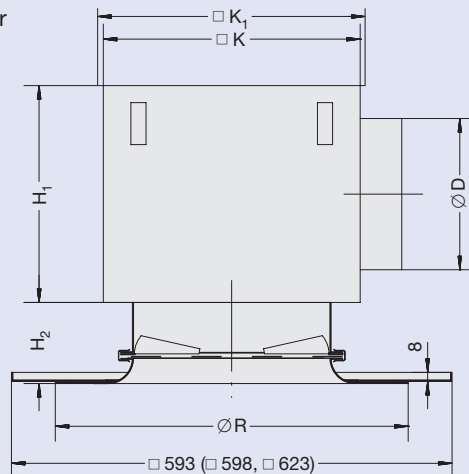

# Installation · Fixing · Materials

## Installation

Standard suspension is via three or four hanging brackets. For construction without plenum box, the circular duct connection must be made by the customer. In Figs. 1 and 3, the swirl diffusers are laid on the T-box from above. In the construction with recessed T-box shown in Fig. 2, the swirl diffuser is inserted into the ceiling from below using the four brackets with turnbuckles.

## Materials

The face plate, diffuser and connection collar are rolled galvanised sheet steel. The discharge nozzle ring is made of sheet steel and the top entry spigot is made of aluminium. The face plates for types DCS-N and DCS-P are pretreated and powder-coated white (RAL 9010). The diffuser is stove-enamelled black (RAL 9005). For the DCS-C type, the face plate and inserted discharge nozzle ring are pretreated and powder-coated white (RAL 9010). The rear diffuser is stove-enamelled black (RAL 9005). The plenum box consists of rolled galvanised sheet steel, with an inner lining of mineral wool.

Fig. 1

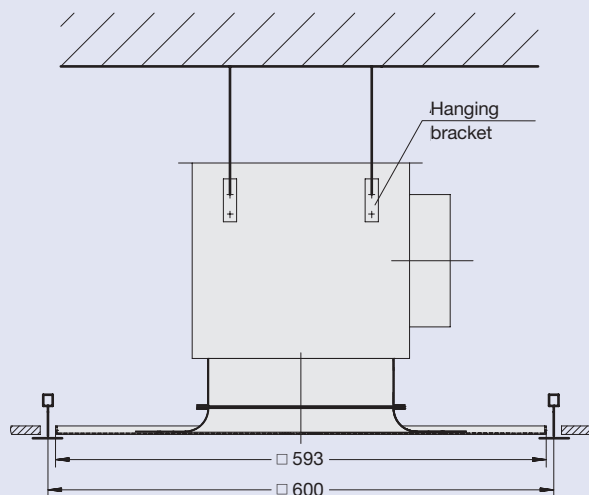

Type DCS-...-V-A or Type DCS-...-V-AK

Fig. 3

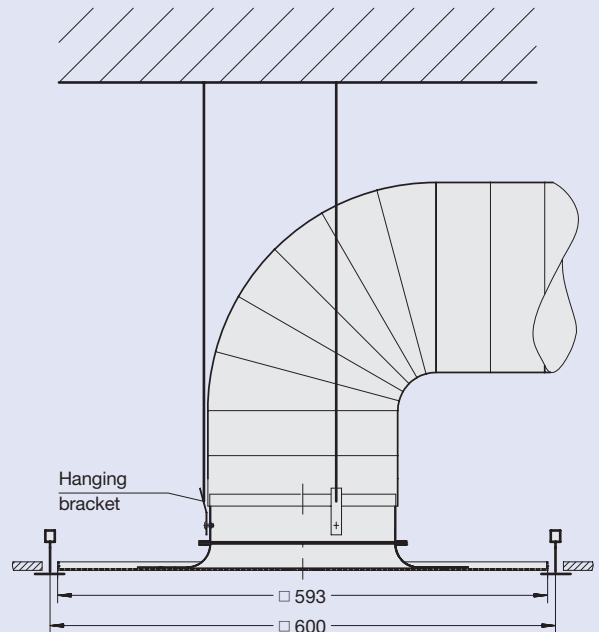

Type DCS-...-V-K

Fig. 2

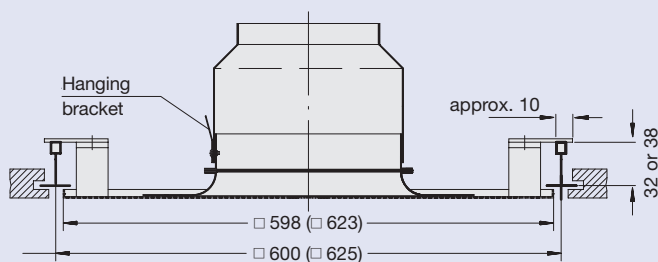

Type DCS-...-H-US



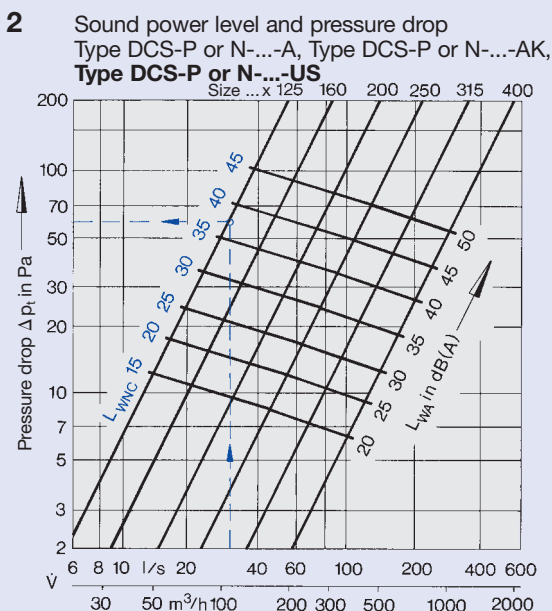
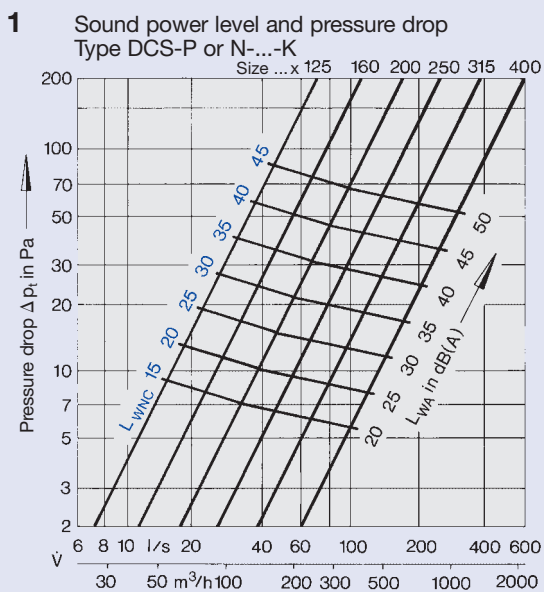

## Corrections for type DCS-C-...

### For diagram 1: Correction for total pressure drop

Type	Size...x	125	160	200	250	315	400
DCS-C-...-K	$\Delta p_t$	x 1.76	x 1.40	x 1.29	x 1.25	x 1.25	x 1.25

### For diagram 1: Correction to sound power level

Type	Size...x	125	160	200	250	315	400
DCS-C-...-K	$L_{WA}$	+ 6	+ 5	+ 4	+ 3.5	+ 3	+ 3
	$L_{WNC}$						

## Corrections for type DCS-C-...

### For diagram 2: Correction for total pressure drop

Type	Size...x	125	160	200	250	315	400
DCS-C-...-A							
DCS-C-...-AK	$\Delta p_t$	x 1.50	x 1.30	x 1.25	x 1.22	x 1.22	x 1.22
DCS-C-...-US							

### For diagram 2: Correction to sound power level

Type	Size...x	125	160	200	250	315	400
DCS-C-...-A	$L_{WA}$ $L_{WNC}$	+ 6	+ 5	+ 4	+ 3.5	+ 3	+ 3
DCS-C-...-AK							
DCS-C-...-US							

# Aerodynamic Data DCS ... x 125

## Example

Given Data: Type DCS-N-V-A/... x 125

Volume flow per diffuser	$\dot{V}$	= 30 l/s
Supply air temperature differential	$\Delta t_z$	= - 8 K
Sound power level in room	$L_{WA}$	= 40 dB(A)
Room height	H	= 3.00 m
Modular grid required	A x B	= 3.20 m x 3.20 m
Distance to wall	X	= 1.60 m

Diagram 2: Sound power level and pressure drop

$L_{WA} = 42$  dB(A)  
 $\Delta p_t = 60$  Pa

The sound power level must be corrected for the number of diffusers and the room absorption.

Diagram 3: Diffuser arrangement B = 2.80 m

A = 3.20 m  
 $H_1 = H - 1.80$  m = 1.20 m  
 at  $\dot{V} = 30$  l/s,  $\bar{v}_{H1} = 0.20$  m/s

Diagram 4: Diffuser arrangement single or more than one row, B  $\geq$  4.00 m

$\bar{v}_{H1} = 0.14$  m/s

Diagram 3 applies to B = 2.80 m and Diagram 4 to B  $\geq$  4.00 m

As B = 3.20 m is specified, we can interpolate between  $\bar{v}_{H1} = 0.20$  m/s and  $\bar{v}_{H1} = 0.14$  m/s.

This gives  $\bar{v}_{H1} = 0.17$  m/s

**3** Diffuser arrangement more than one row if B = 2.80 m

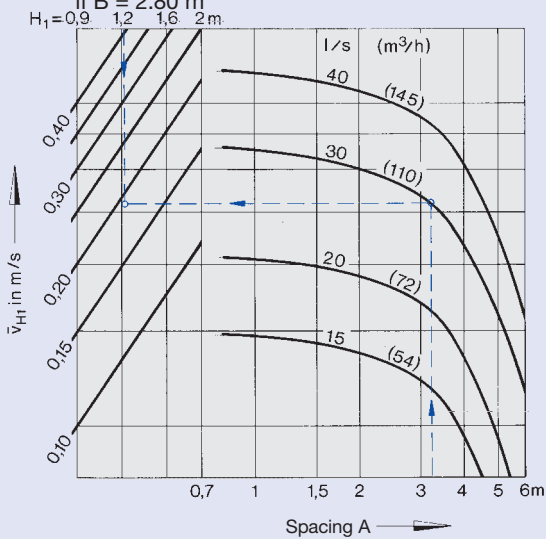

**5** Air velocity at wall and temperature quotient

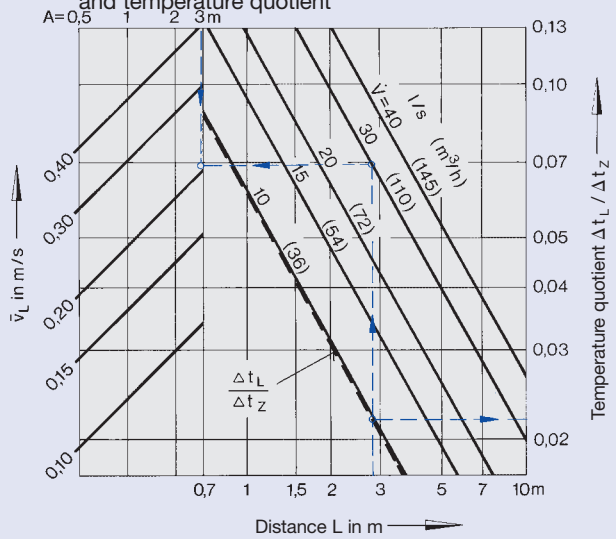

**4** Diffuser arrangement single or more than one row if B  $\geq$  4.00 m

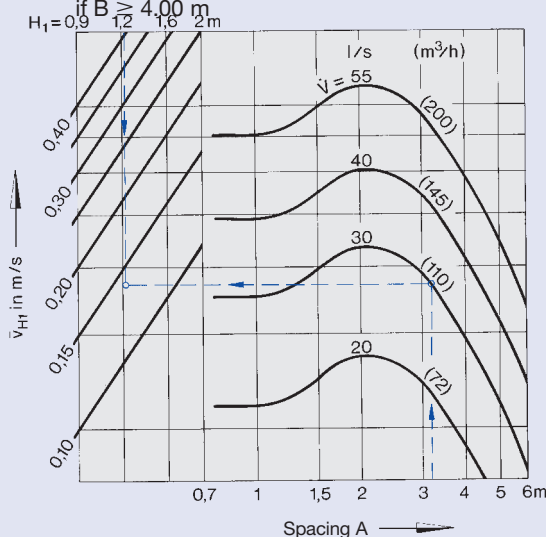

**6** Diffusers arranged in a Square

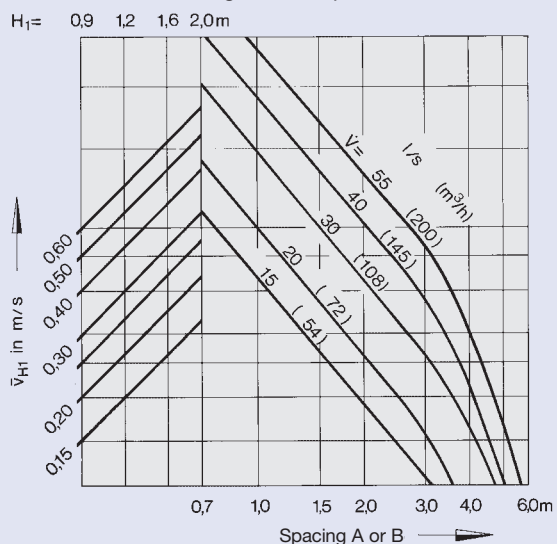

# Aerodynamic Data DCS ... x 160

Diagram 5: Air velocity at wall and temperature quotient

$$L = X + H_1 = 1.60 + 1.20 = 2.80 \text{ m}$$

$$A = 3.20 \text{ m}$$

Line A = 3.00 m also applies to all values above 3.00 m!

Air velocity at a distance of 75 mm from wall

$$\bar{v}_L = 0.21 \text{ m/s}$$

$$L = X + H_1 = 2.80 \text{ m}$$

$$L = A/2 + H_1 = 2.80 \text{ m}$$

$$\Delta t_L / \Delta t_z = 0.022$$

$$\Delta t_L = 0.022 \times (-8 \text{ K}) = -0.18 \text{ K}$$

Correction for diagrams 3 to 10:  
For type DCS-C, the values  $\bar{v}_{H1}$ ,  $\bar{v}_L$  and  $\Delta t_L / \Delta t_z$

**7** Diffuser arrangement more than one row if  $B = 2.80 \text{ m}$

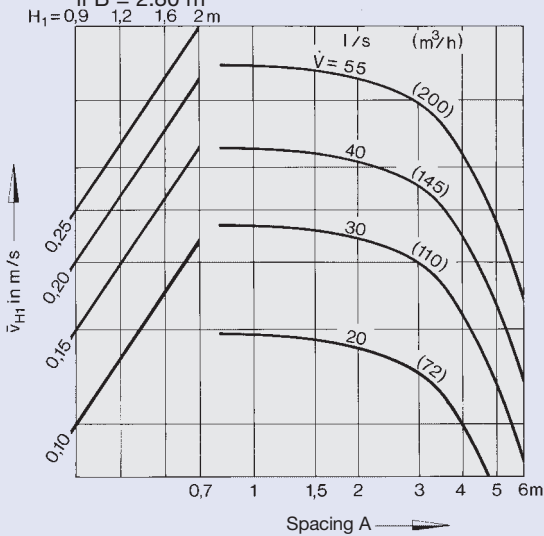

**9** Air velocity at wall and temperature quotient

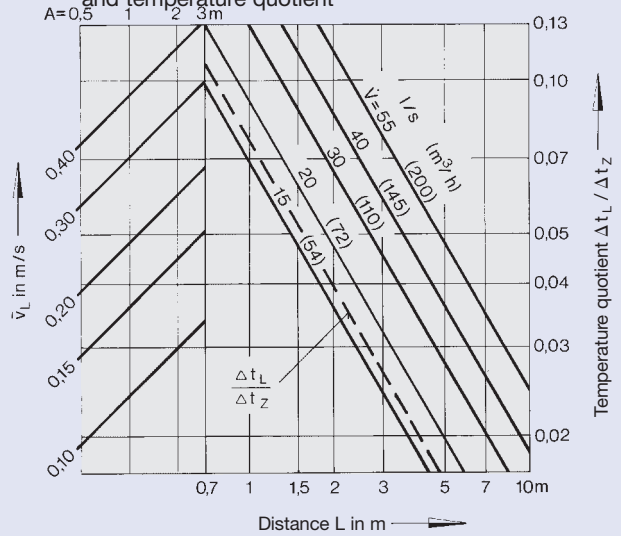

**8** Diffuser arrangement single or more than one row if  $B \geq 4.00 \text{ m}$

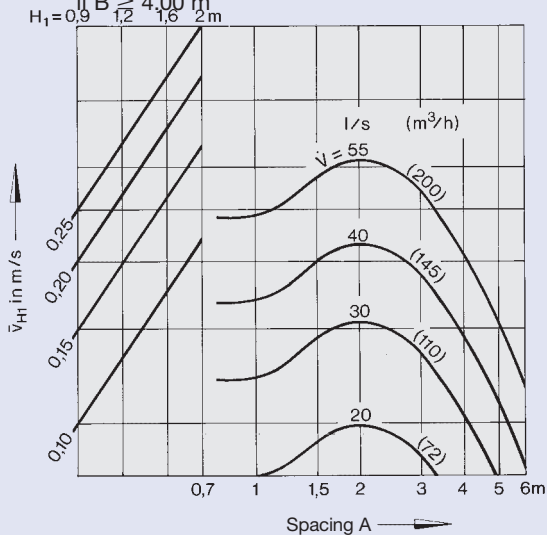

**10** Diffusers arranged in a Square

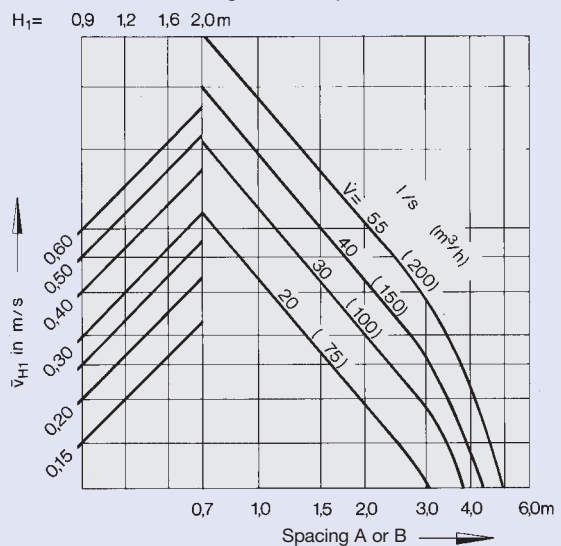

**11** Diffuser arrangement more than one row  
if  $B = 2.80$  m

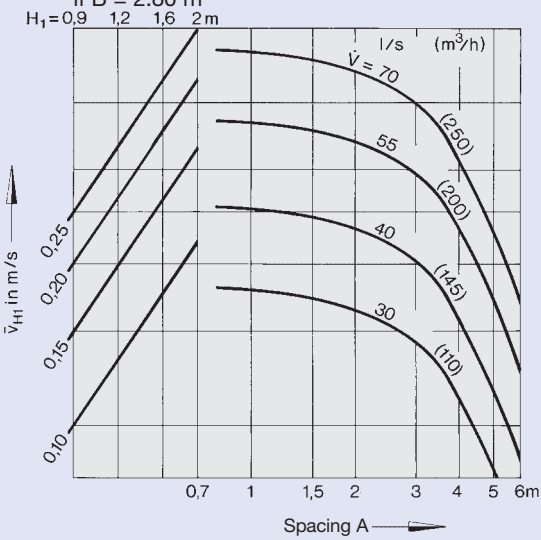

**13** Air velocity at wall  
and temperature quotient

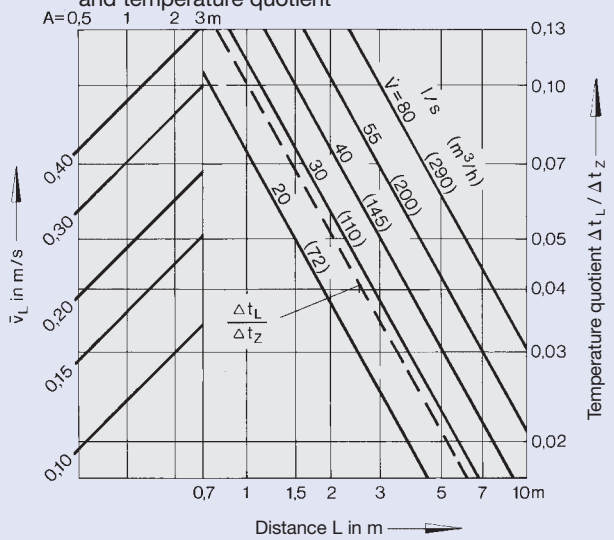

**12** Diffuser arrangement single or more than one row  
if  $B \geq 4.00$  m

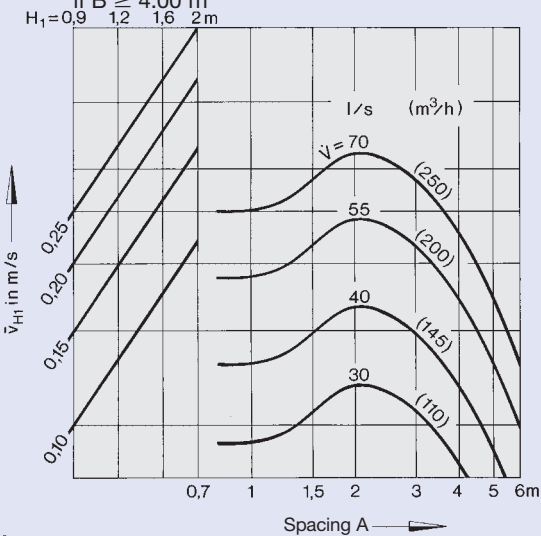

**14** Diffusers arranged in a Square

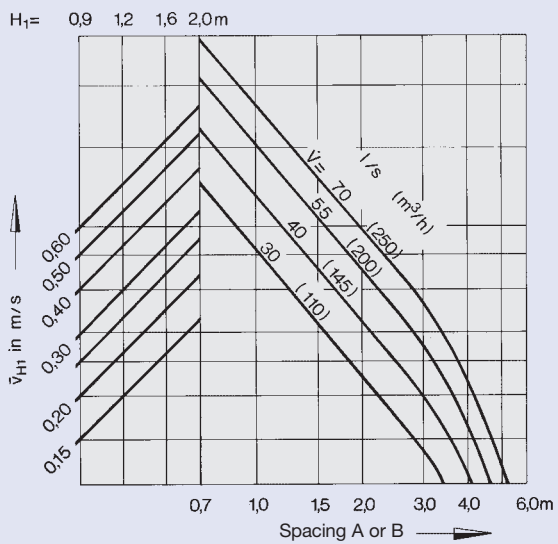

**Correction for diagrams 11 to 18:**  
 For type DCS-C, the values  $\bar{v}_{H1}$ ,  $\bar{v}_L$  and  $\Delta t_L / \Delta t_z$

**15** Diffuser arrangement more than one row  
 if  $B = 2.80$  m

$H_1 = 0.9, 1.2, 1.6, 2.0$  m

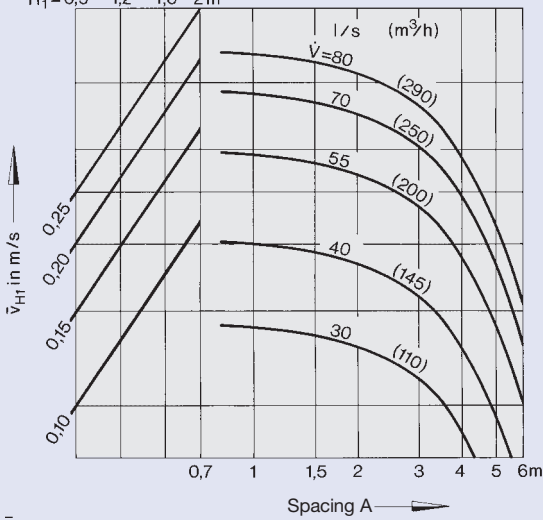

**17** Air velocity at wall  
 and temperature quotient

$A = 0.5, 1, 2, 3$  m

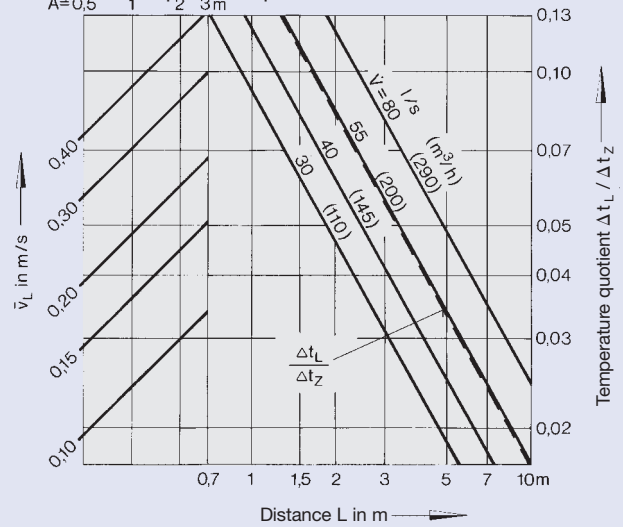

**16** Diffuser arrangement single or more than one row  
 if  $B \geq 4.00$  m

$H_1 = 0.9, 1.2, 1.6, 2.0$  m

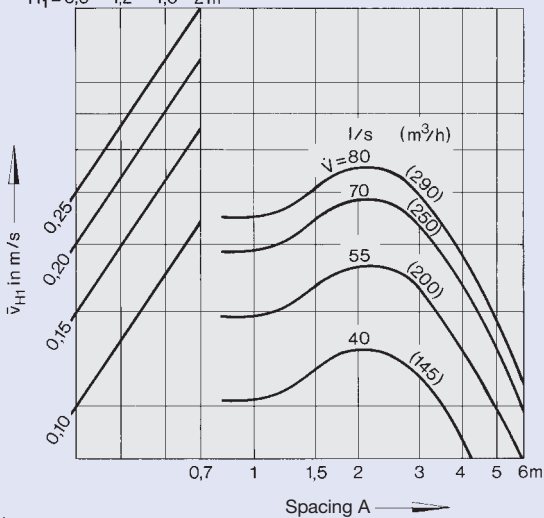

**18** Diffusers arranged in a Square

$H_1 = 0.9, 1.2, 1.6, 2.0$  m

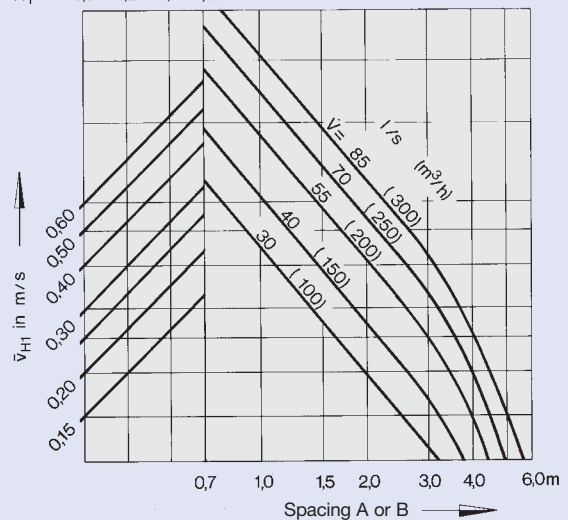

**19** Diffuser arrangement more than one row  
if  $B = 2.80$  m

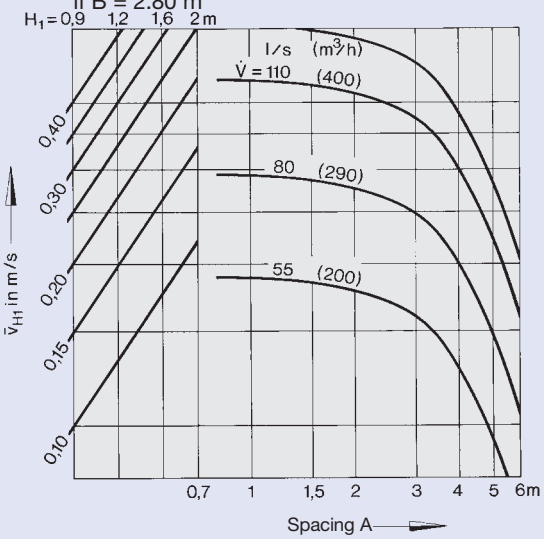

**21** Air velocity at wall  
and temperature quotient

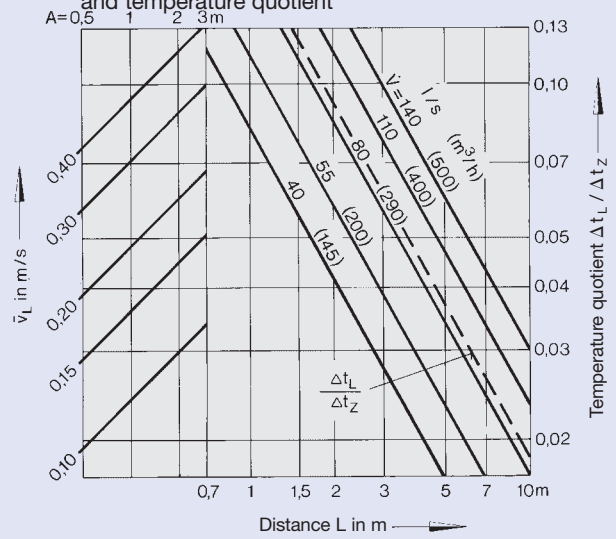

**20** Diffuser arrangement single or more than one row  
if  $B \geq 4.00$  m

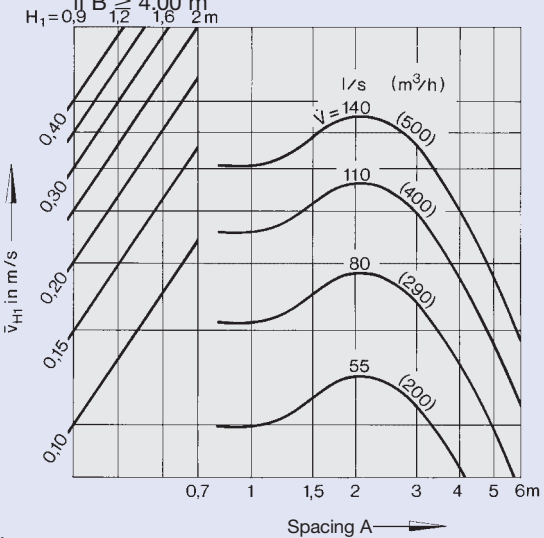

**22** Diffusers arranged in Square

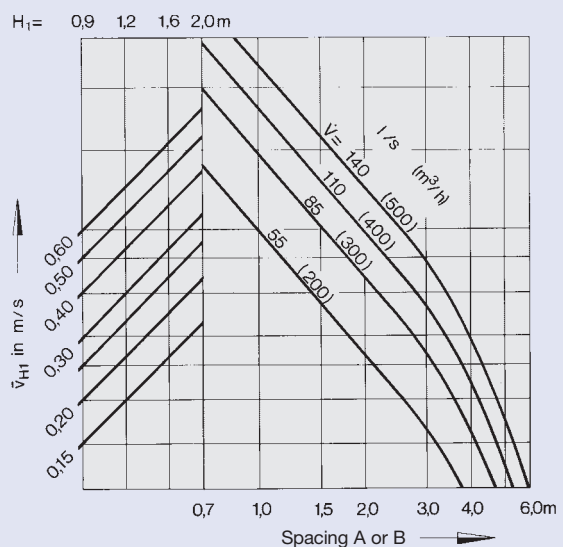

**Correction for diagrams 19 to 26:**  
 For type DCS-C, the values  $\bar{v}_{H1}$ ,  $\bar{v}_L$  and  $\Delta t_L / \Delta t_z$

**23** Diffuser arrangement more than one row  
 if  $B_1 = 2.80$  m  
 $H_1 = 0.9, 1.2, 1.6, 2$  m

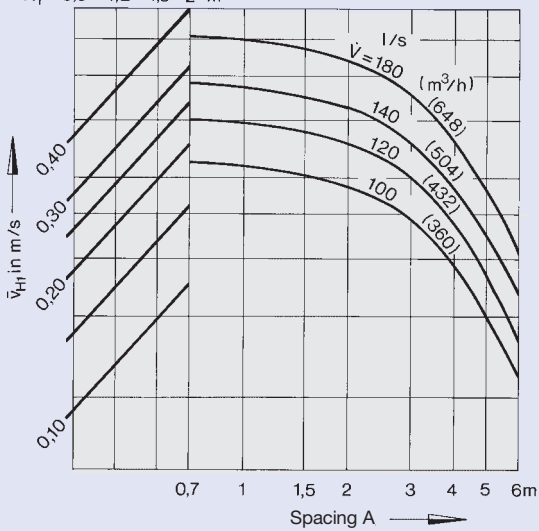

**25** Air velocity at wall  
 and temperature quotient  
 $A = 0.5, 0.7, 1, 2, 3$  m

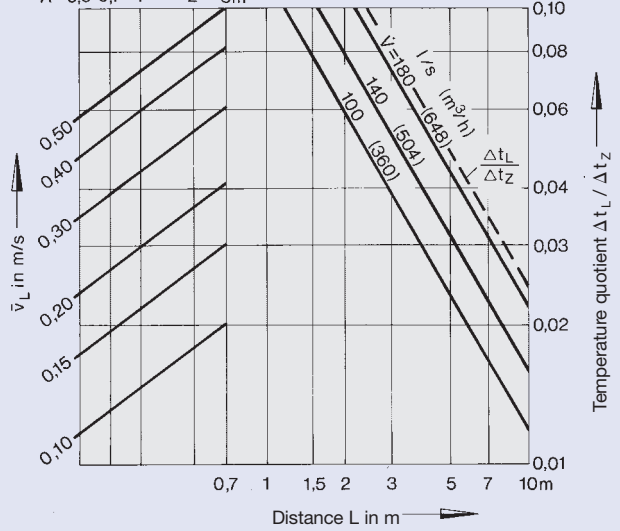

**24** Diffuser arrangement single or more than one row  
 if  $B_1 \geq 4.00$  m  
 $H_1 = 0.9, 1.2, 1.6, 2$  m

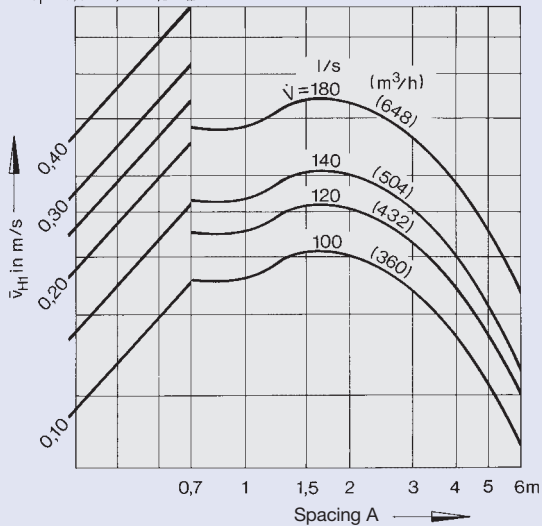

**26** Diffusers arranged in a Square

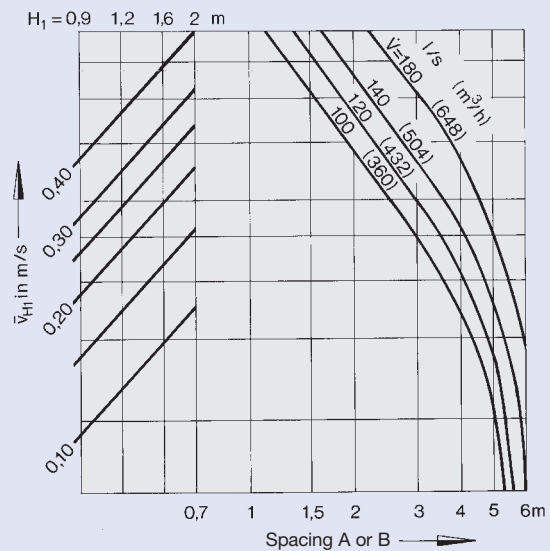

# Order Details

## Order Code

These codes do not need to be completed for standard products

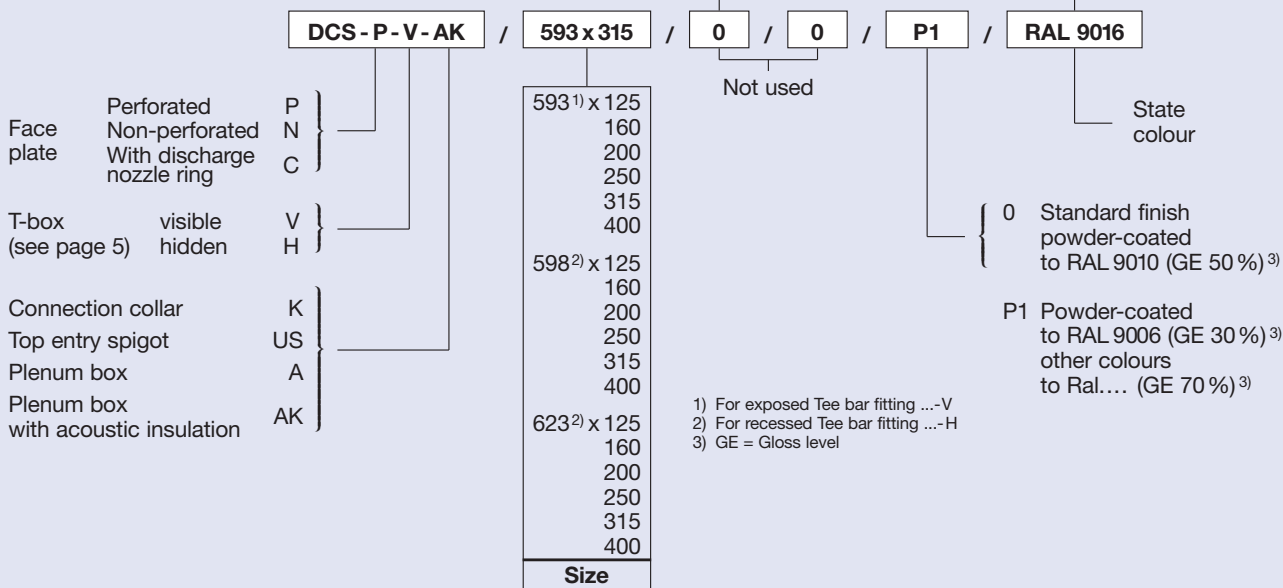

## Specification Text

Square ceiling mounted swirl diffuser providing horizontal high induction swirling discharge, consisting of a perforated face plate (50 % free area) with a thin acoustic fleece rear lining – type DCS-P; alternatively type DCS-N with plain plate and returned edge and with central perforated sheet insert or type DCS-C with plain plate and returned edge and with central discharge nozzle and recessed perforated plate. Rear diffuser with radially fixed air control blades and connection collar. If required, can be supplied with top entry spigot piece with hanging brackets or side entry plenum box with circular spigot and hanging brackets. Plenum box can have internal acoustic insulation if specified.

## Materials:

The face plate, diffuser and connection collar are rolled galvanised sheet steel. The discharge nozzle ring is made of sheet steel and the top entry spigot is made of aluminium. The face plates for types DCS-N and DCS-P are pretreated and powder-coated white (RAL 9010). The diffuser is stove-enamelled black (RAL 9005). For the DCS-C type, the face plate and inserted discharge nozzle ring are pretreated and powder-coated white (RAL 9010). The rear diffuser is stove-enamelled black (RAL 9005). The plenum box consists of rolled galvanised sheet steel, with an inner lining of mineral wool.

## Order Example

Make: TROX  
Type: DCS - P - V - AK / 593 x 315 / P1 / RAL 9016