



Active chilled beams

Type DID614

TROX GmbH

Heinrich-Trox-Platz

D-47504 Neukirchen-Vluyn

Phone: +49 (0) 2845 202-0

Fax: +49 (0) 2845 202-265

E-mail: trox-de@troxgroup.comInternet: [http://www.trox-](http://www.trox-technik.com)[technik.com](http://www.trox-technik.com)

Product overview

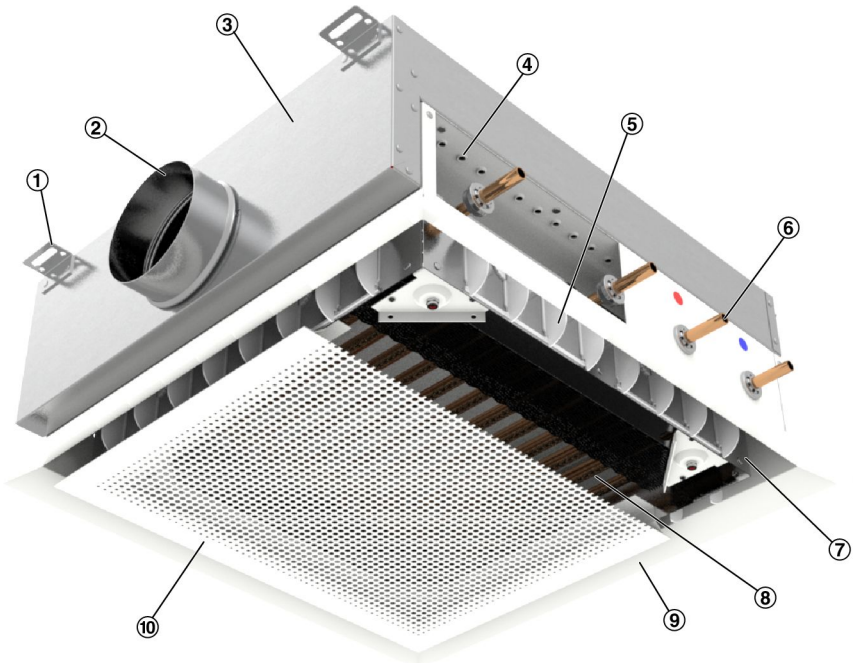

Fig. 1: Schematic illustration of DID614

- | | | | |
|---|-----------------------------------|---|---------------------|
| ① | Hanging brackets | ⑥ | Water connections |
| ② | Primary air spigot | ⑦ | Encasing (optional) |
| ③ | Casing | ⑧ | Heat exchanger |
| ④ | Nozzle plate with punched nozzles | ⑨ | Front frame |
| ⑤ | Air control blades (optional) | ⑩ | Induced air grille |

Important notes

Information on the installation manual

This manual enables operating or service personnel to correctly install the product described below and to use it safely and efficiently.

It is essential that these individuals read and fully understand this manual before starting any work. The basic prerequisite for safe working is to comply with the safety notes and all instructions in this manual.

The local regulations for health and safety at work and general safety regulations also apply.

Qualified staff

Trained personnel

Trained personnel are individuals who have sufficient professional or technical training, knowledge and actual experience to enable them to carry out their assigned duties, understand any potential hazards related to the work under consideration, and recognise and avoid any risks involved.

Limitation of liability

The information in this manual has been compiled with reference to the applicable standards and guidelines, the state of the art, and our expertise and experience of many years.

The manufacturer does not accept any liability for damages resulting from:

- Non-compliance with this manual
- Incorrect use
- Operation or handling by untrained individuals
- Unauthorised modifications

The actual scope of delivery may differ from the information in this manual for special constructions, additional order options or as a result of recent technical changes.

Personal protective equipment

Personal protective equipment must be worn for any work in order to reduce health or safety hazards to the minimum.

The appropriate protective equipment for a job must be worn for as long as the job takes.

Industrial safety helmet



Industrial safety helmets protect the head from falling objects, suspended loads, and the effects of striking the head against stationary objects.

Protective gloves



Protective gloves protect hands from friction, abrasions, punctures, deep cuts, and direct contact with hot surfaces.

Safety shoes



Safety shoes protect the feet against crushing, falling parts, and slipping on slippery ground.

Correct use

Active chilled beams provide centrally conditioned primary air (fresh air) to the room. Heat exchangers are used for additional cooling and/or heating.

Incorrect use**WARNING!****Danger due to incorrect use!**

Incorrect use of the unit can lead to dangerous situations.

Never use the unit:

- in areas with potentially explosive atmospheres (EX)
- in humid rooms
- in rooms with aggressive or dust-laden air

Technical data

Description	Value
Primary air volume flow rate	9 – 97 l/s, 32 – 350 m³/h
Cooling capacity	up to approx. 2150 W
Heating capacity	up to approx. 2000 W
Max. operating pressure, water side	6 bar
Max. operating temperature	75 °C (55 °C when using flexible connecting hoses)
Minimum operating temperature	6 °C

Dimensions

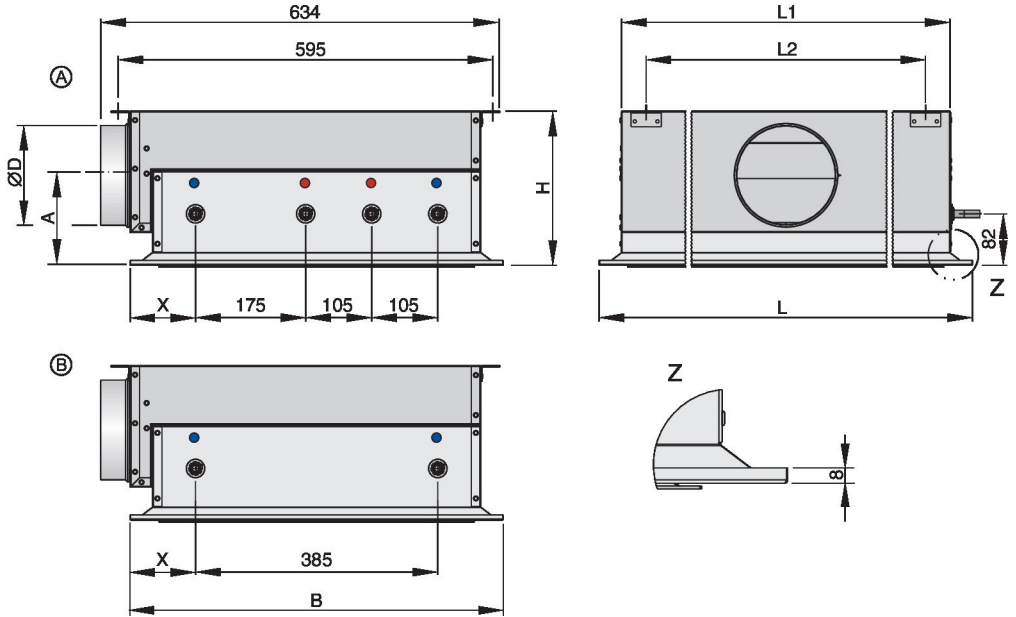

Fig. 2: Dimensional drawing of DID614

- Ⓐ 4-pipe
- Ⓑ 2-pipe

Variants for ceiling installation

Dimensions [mm]					
L		B	L ₁	L ₂	X
593	×	593	522	444	104
598	×	598	522	444	106.5
618	×	618	522	444	116.5
623	×	623	522	444	119
1193	×	593	1122	1044	104
1198	×	598	1122	1044	106.5
1243	×	618	1147	1069	116.5
1248	×	623	1147	1069	119

L = total length (diffuser face), B = total width (diffuser face)

Variants for freely suspended installation

Dimensions [mm]					
L		B	L ₁	L ₂	X
900	×	900	522	444	257.5
1525	×	900	1147	1069	257.5

L = total length (diffuser face), B = total width (diffuser face)

Dimensions [mm]		
ØD	A	H
123	125	230
158	143	245
198	163	285

Weight [kg]		
Nominal size [mm]	DID614	Contained water
600 × 600	16	2
1200 × 600	30	3
1250 × 625	31	3
900 × 900	21	2
1525 × 900	38	3

Transport and storage

Transport

CAUTION!

Danger of injury from sharp edges, sharp corners and thin sheet metal parts!

Sharp edges, sharp corners and thin sheet metal parts may cause cuts or grazes.

- Be careful when carrying out any work.
- Wear protective gloves, safety shoes and a hard hat.

NOTICE!

Carry the unit in pairs in order to prevent any damage.

Storage

Please note:

- Store the unit only in its original packaging
- Protect the unit from the effects of weather
- Protect the unit from humidity, dust and contamination
- Storage temperature: -10 to 50 °C
- Relative humidity: 95 % max., non-condensing

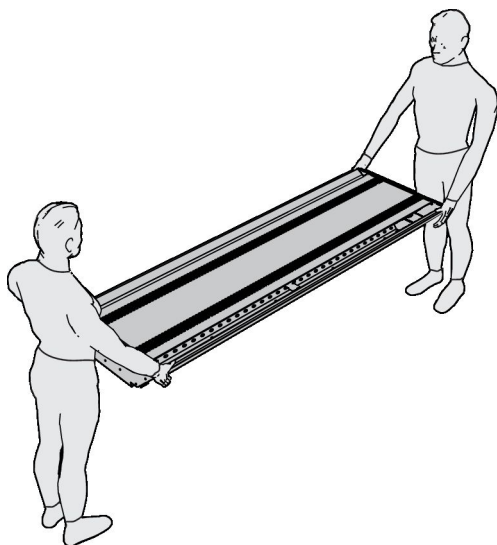

Fig. 3: Carrying the unit in pairs

Use only lifting and transport gear designed for the required load. Always secure the load against tipping and falling.

Upon delivery, carefully remove the packaging and check the unit for transport damage and completeness.

Ceiling installation

Ceiling systems

Active chilled beams are typically installed in suspended ceilings. Installation in the most common ceiling systems is shown below.

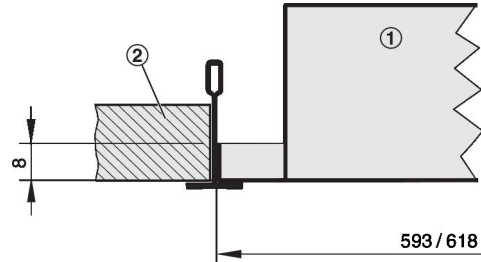

Fig. 4: Ceiling installation, T-bar

- ① DID614
- ② Ceiling tile

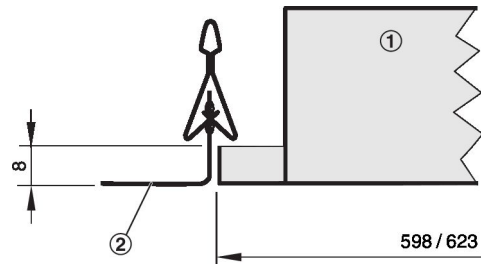

Fig. 5: Ceiling installation, clamping profile

- ① DID614
- ② Ceiling tile

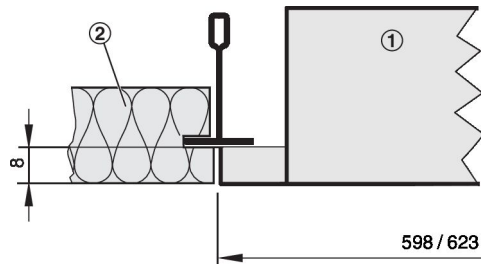

Fig. 6: Ceiling installation, concealed T-bar

- ① DID614
- ② Ceiling tile

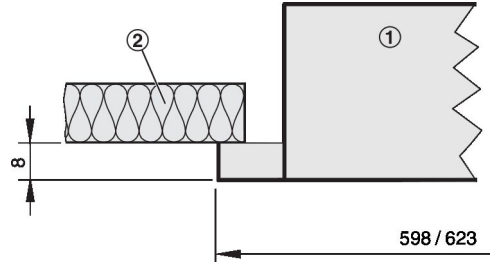

Fig. 7: Ceiling installation, plasterboard ceiling

- ① DID614
- ② Plasterboard ceiling

Installing the unit

Personnel:

- Trained personnel

Protective equipment:

- Industrial safety helmet
- Safety shoes
- Protective gloves

If possible, install the unit before fixing the ceiling tiles; if this is not possible, remove the adjacent ceiling tiles.

Only work in pairs; preferably use a lift.



DANGER!

Danger of death from the fall of suspended loads!

- Only use fixing materials designed for the required load.
- Use all hanging brackets supplied.
- Stand clear of suspended loads, unless properly secured.
- Check secure fixing after installation.

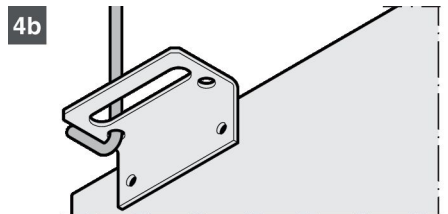
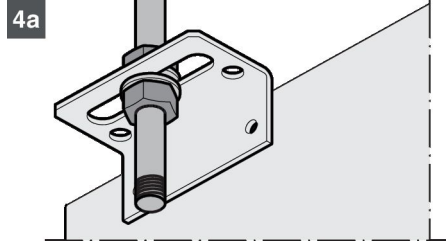
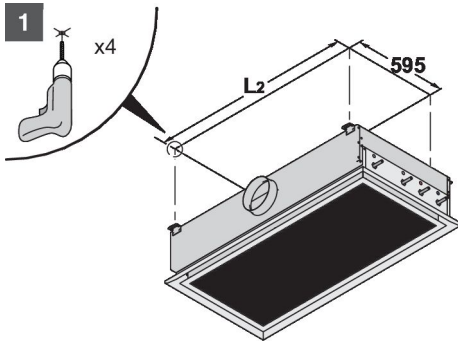
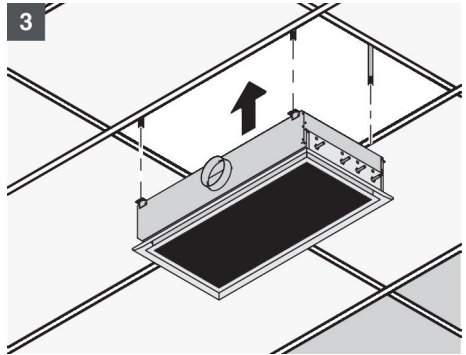
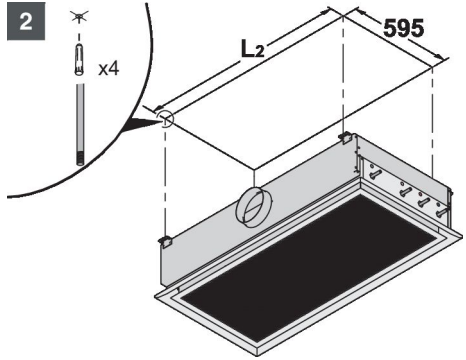

Connecting heat exchanger

Personnel:

- Trained personnel

Protective equipment:

- Industrial safety helmet
- Safety shoes
- Protective gloves

Heat exchanger variants

- **2-pipe system**
 - 2 water connections for connection to the hot or cold water circuit
 - Operating mode: either cooling or heating
 - A changeover valve allows for changing over between heating and cooling in changeover mode.
- **4-pipe system**
 - 4 water connections for connection to the hot and cold water circuit
 - 2 operating modes: cooling and heating

Marking of the water connections

- (blue) - Cold water circuit
- (red) - Hot water circuit

Water flow and return flow can be selected (in the respective circuit)

Make sure that the water temperature does not fall below the dew point.

Pipe connection on the unit	SW	Type of connection
Copper tubes 12 × 1 mm	–	Soldered (rigid) Flexible hoses
G 1/2" external thread and flat seal	22	Screw connection (rigid) Flexible hoses
G 1/2" union nut and flat seal	24	Screw connection (rigid) Flexible hoses

We recommend connecting with flexible hoses (accessories)

Screw connection (flexible hoses or screw connection)

- Ensure that the surfaces are clean
- Insert seal and tighten screw connection by hand.

There is a risk of damage to the heat exchanger if it is not installed correctly!

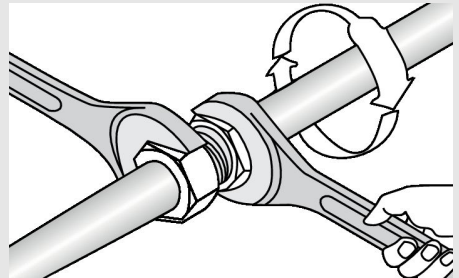

Always use a suitable tool to counter the tightening force in order to prevent any damage.

Soldered joint

Clean the pipe ends and make a proficient solder joint.

Filling the heat exchanger

! NOTICE!

Subzero temperatures will damage the heat exchanger!

Only fill the heat exchanger if there is no danger of freezing.

Fill the heat exchanger and vent it. To fill the system, use clean tap water (pH value 6.5 to 9) or a water glycol mixture (max. 30% glycol).

Check the system for leaks immediately after installation and then at regular intervals.

Connecting the ductwork

Active chilled beams are fitted with a primary air (fresh air) spigot.

Spigots are suitable for circular ducts according to EN 1506 or EN 13180.

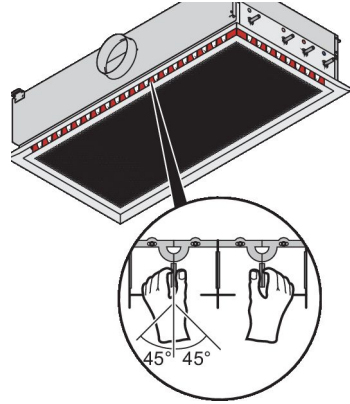
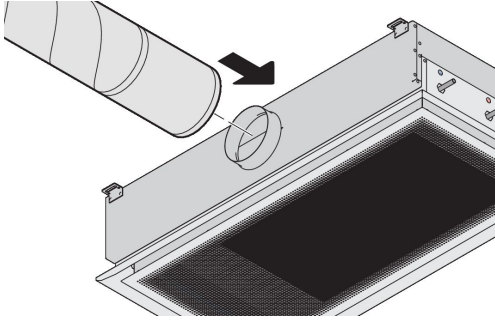

Commissioning

Before you start commissioning:

- Check active chilled beams for correct position
- Remove protective films, if any
- Ensure that all connections are correct
- Ensure that all active chilled beams are clean and free from residues and foreign matter
- Ensure that the water system including the heat exchanger has been filled and vented

Adjusting the air control blades

The air discharge pattern can be changed by adjusting the optional air control blades in 15° increments up to 45° to the left or right.

Three air distribution patterns can be set.

Fig. 8: Changing the air discharge pattern

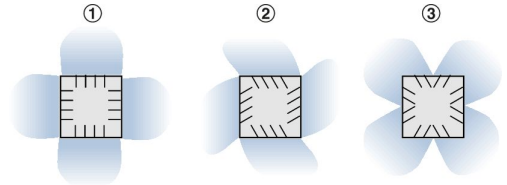

Fig. 9: Examples

- ① Straight air discharge
- ② Angled air discharge
- ③ Divergent air discharge

! NOTICE!

Incorrect handling will damage the air control blades!

To avoid any damage, always use both hands to adjust the air control blades.

Adjusting the nozzles

The DID614 is fitted with adjustable twin nozzles that allow for adapting the airflow velocity to changed operating conditions at a later stage, if required.

CAUTION!

Hot surfaces!

Danger of burn injuries when working on the hot water system.

Before working on the water-side connections, shut down the system and let it cool down.

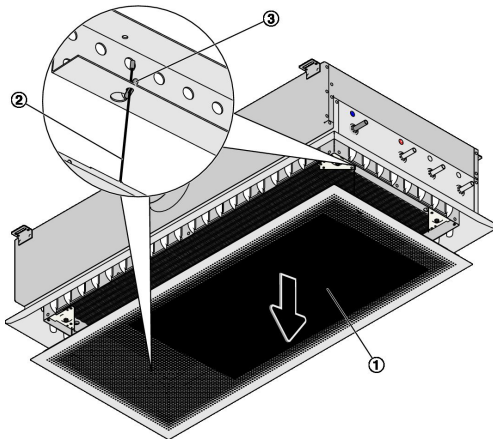

Fig. 10: Opening the induced air grille

- ▶ To open the induced air grille (Fig. 10/1), pull it down. To completely remove the grille, unhook the safety cables (Fig. 10/2) by pulling them down with the retaining plates (Fig. 10/3).

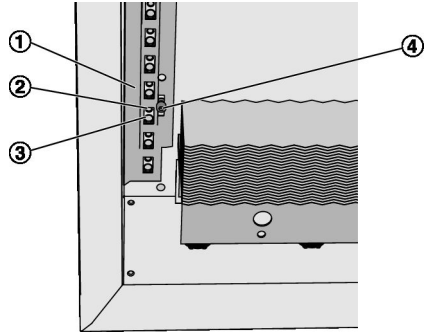

Fig. 11: Adjusting the nozzles on the DID614

- ▶ Loosen the Allen screws (SW4) (Fig. 11/4) of the flat adjustment bar (Fig. 11/1).
- ▶ Slide the flat adjustment bar back or forth to open or close the nozzles as required:
 - small nozzle open (Fig. 11/2) (DS)
 - large nozzle open (Fig. 11/3) (DB)
 - both nozzles open (DA, factory setting)
- ▶ Manually tighten the Allen screws of the flat adjustment bar.
- ▶ Fix the induced air grille.

Cleaning

Cleaning the casing

The casing may be cleaned with a damp cloth. Sticky dirt or contamination may be removed with a commercial, non-aggressive cleaning agent. Cleaning agents that contain chlorine must not be used.

Cleaning the heat exchanger

Personnel:

- Trained personnel

Protective equipment:

- Industrial safety helmet
- Safety shoes
- Protective gloves

1. ▶ Remove the induced air grille,
 ↪ on page 11

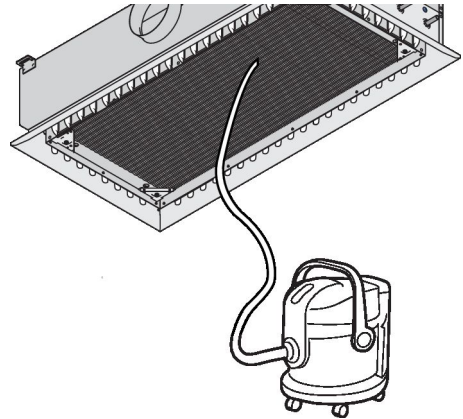

Fig. 12: Cleaning the heat exchanger

2. ▶ Carefully clean the heat exchanger with an industrial vacuum cleaner. Be careful to not damage any blades. We recommend using a soft brush with the suction inlet for cleaning.
3. ▶ After cleaning, reattach the safety cables, and screw-fix and close the grille.



CAUTION!

Danger of head injuries from the fall of the induced air grille!

Check that the induced air grille and safety cables are securely fixed!